

Numerical and Experimental Study of Counter Flow Cooling Tower Performance with Difference Packs Porosity and Configuration

Dr. D. Al. D.H. Alwan

Dr. I. W. Maid

A. H. Soheel

Technical college / Baghdad

Abstract

This study presents an experimental and numerical investigation of the performance of a forced draft counter flow cooling tower with two kinds of wire mesh packing. The packing used in this study is wire mesh with small square holes (WMSSHSP) and expanded wire mesh with diamond holes (EWMDHSP) configurations. In the numerical investigation, the two dimensional CFD model with finite volume scheme has utilized the standard ($k - \epsilon$) turbulence model to computes the air properties, while one-dimensional model is used to get the water properties. From the results it is concluded that the (EWMDHSP) enhance the performance of the cooling tower. That is due to the pressure drop in the (WMSSHSP) is higher than that for the (EWMDHSP) because air resistance of the former pack is higher than the latter pack. The agreement seems to be acceptable between the numerical and the experimental results.

Keywords: cooling tower, packing, wire mesh, performance, heat and mass transfer

دراسة عددية وتجريبية لأداء برج تبريد متعاكس الجريان لأنواع الحشوات ذات مسامية وتنظيم مختلفة

عمار حسن سهيل

د. اصبيح وسمي مايد

د. ضياء الدين حسين علوان

الكلية التقنية / بغداد

الخلاصة

يتناول هذا البحث دراسة أداء برج تبريد ماء قسري متعاكس الجريان باستخدام حشوة من نوع شبكة سلكية و كانت الحشوة المستخدمة على نوعين مختلفين بالشكل حيث كانت الأولى ذات فتحات مربعة صغيرة (شبكة سلكية ذات ثقوب مربعة صغيرة) والثانية ذات فتحات معينيه كبيرة (شبكة سلكية ذات ثقوب معينيه متوسطه). في الدراسة العددية تم بناء موديل ديناميكي حسابي للجريان CFD ثنائي البعد، وباستخدام طريقة الحجوم المحددة وممثل فيه موديل الاضطراب ($k - \epsilon$) لحساب خواص الهواء وخواص الماء (حيث أن خواص الماء أحادية البعد). تم التوصل إلى أن الحشوة الشبكية السلكية ذات الفتحات المعينيه الكبيرة تعطي أكثر كفاءة للبرج من الحشوة الشبكية السلكية ذات الفتحات المربعة الصغيرة وذلك بسبب انخفاض الضغط في الحشوة الثانية أكبر من انخفاض الضغط في الحشوة الأولى.

Received: 2 – 1 - 2013

Accepted: 17 – 5 - 2013

Nomenclature:**Abbreviations:**

EWMDHSP Expanded wire mesh with diamond holes shape packing

WMSSHSP Wire mesh with small square holes shape packing

Symbols:

A Area (m^2).

a_E, a_W, a_N, a_S Coefficients of finite volume equation (kg/s).

$C_\mu, C_{1\epsilon}, C_{2\epsilon}$ Turbulent empirical constants.

f_x, f_y Resistance to air flow in x-, and y-direction respectively (N/m^3).

g Gravitational acceleration (m/s^2).

h_a Enthalpy of air-water vapor mixture at wet bulb temperature (kJ/kg_{da}).

h_{sw} Enthalpy of air-water vapor mixture at bulk water temperature (kJ/kg_{da}).

h_w Enthalpy of water (kJ/kg).

k Turbulent kinetic energy (m^2/s^2).

Ka Volumetric mass transfer coefficient ($kg/m^3.s$).

m_v''' Rate of mass transfer per unit volume ($kg/m^3.s$).

N Constant depending on the packing design.

N_{elim} Velocity head lost in the eliminator.

n Empirical constant specific to a particular tower design.

P Pressure (N/m^2).

Pr Prandtl number

q''' Rate of heat transfer per unit volume (W/m^3).

R Universal gas constant ($J/k_{mol}.K$).

S_{SC}, S_P Components of source term of finite volume equation.

t_{adb} Air dry bulb temperature ($^{\circ}C$).

u, v Air velocity component in x- and y-direction respectively (m/s).

V Active cooling volume per unit plan area of packing (m^3/m^2).

w_G Molecular weight of moist air (kg/k_{mol}).

w_{sw} Moisture fraction of saturated moist air (kg/kg_{da}).

w_a Moisture fraction of moist air (kg/kg_{da}).

Subscripts:

E, W, N, S Values at, East, West, North, and South for the control points.

P Control point.

Greek symbols:

ρ Density of moist air (kg/m^3).

ρ_{amb} Density of ambient air (kg/m^3).

$\sigma_k, \sigma_\epsilon$ Constants for the ($k - \epsilon$) model.

ϵ Turbulent energy dissipation rate (m^2/s^3).

λ Constant depending on the packing design.

$\Gamma_k, \Gamma_\epsilon$ Diffusion coefficient for kinetic energy and dissipation ($kg/m.s$).

Γ_{eff} Effective exchange coefficient ($kg/m.s$).

ϕ Dependent variable.

μ, μ_t Dynamic viscosity for laminar and turbulent flow ($kg/m.s$).

μ_{eff} Effective viscosity ($kg/m.s$).

σ_{eff} Effective Prandtl number.

Introduction:

The function of the cooling tower is to cool water by bringing it into direct contact with air. This cooling is accomplished by a combination of sensible heat transfer and evaporation of a small portion of water. Due to heat and mass transfer, the water temperature is reduced while the air enthalpy is increased. In order to ensure high performance in the cooling tower packing, it is essential that the area of water film surface in contact with the air, and the time of contact are as great as possible and the pressure drop is as least as possible. The contact time and area between air and water are increased by spraying water over a fill, and passing air through the fill. The counter flow and fan are commonly used in a mechanical draft tower.

Majumdar, et al, (1983) [1] discuss the limitations of current practices of evaluating thermal performance of wet cooling towers and describes a more advanced mathematical model for natural and mechanical cooling tower in two dimensions. Al-Habobi, (1995) [2] studied the performance ceramic blocks and asbestos sheets packing for counter flow water cooling tower numerically and experimentally and the results show that, the performance of asbestos sheets exceeds that of ceramic blocks about 5.8 %. Stefanovic et al,(2001) [3] presented the results of a 3-D model numerical simulation of heat and mass transfer processes in wet cooling towers and physical and mathematical models are presented in sufficient measure. Abdullah (2002) [4] studied numerically the open type forced draft water cooling towers in 2-D. The accurate flow field for air through the tower was plotted and the accurate behavior of air and water properties was found. Al Saghar (2003) [5] conducted 2-D study of numerical and experimental forced draft water cooling tower. The flow field velocity vector for air through the tower is plotted and accurate behavior of both air and water properties were found. Mehdi Q. (2004) [6] conducted a theoretical and experimental study for mechanical forced draft counter flow cooling tower with using two different types of packing (aluminum and ceramic) and the numerical result shows that the aluminum fills is more effective than ceramic fill in heat and mass transfer between the water and the bulk air. Al waked R. and Behnia M. (2006) [7] investigated the heat and mass transfer inside a natural draft wet cooling tower numerically under different operating and crosswind conditions with 3-D CFD model has utilized the standard k-e turbulence model as turbulence closure. Ahmed A. (2008) [8] investigated the performance of heat and mass transfer of a counter flow water cooling tower theoretically and experimentally and the results of this analysis show that the values of heat and mass transfer coefficients are changeable along the packing height and the vertical flat plates type packing has higher efficiency than the one with horizontal flat plates type packing. Ramkumar R. and Ragupathy A. (2011) [9] investigated the thermal performance of forced draft counter flow wet cooling tower experimentally with expanded wire mesh vertical and horizontal orientation types packing, the vertical orientation wire mesh packing is having better performance than horizontal orientation wire mesh packing .

A forced draft counter water flow cooling tower will be employed. A theoretical and experimental study will be carried out on this tower. In theoretical part a thermal solution (heat and mass balance) will be used to solve the governing equations using finite volume method based on computational fluid dynamics (CFD). The effect of air flow rate and water flow rate for two type's packing different with configuration on the tower performance will be predicated. Experimentally several tests on a counter flow cooling tower test plant will be conducted. These tests will quantify the previous effects and justify the CFD program.

Physical model:

In a counter flow cooling tower water flows downwards and air streams upward. In direct contact of humid air and water surface simultaneous heat and mass exchange is taking place between these two media. When water is cooled in cooling tower the total heat is an algebraic sum of convective and evaporative heat. Convective heat transfer is characterized by temperature difference of water and air, while evaporative heat transfer takes place because of evaporative water mass transfer into humid air.

Merkel's [10] theory states that the rate of heat transfer at any point in the tower is proportional to the difference between the total heat of saturated air at the water temperature and the total heat of the bulk air stream.

$$q''' = Ka(h_{sw} - h_a) \quad \dots\dots (1)$$

where (Ka) is an empirical mass transfer coefficient and can be determined from experimental work, and $(h_{sw} - h_a)$ is the difference between the enthalpies of the saturated air and dry air. An expression of evaporation rate, (m_v''') is :

$$m_v''' = Ka(w_{sw} - w_a) \quad \dots\dots (2)$$

The flow resistance offered by various solid obstacles and water flow within the tower is expressed for each control cell in the following integrated form:

$$\int f_x dV = N \cdot \frac{1}{2} \rho u^2 \Delta V + N_{elim} \frac{1}{2} \rho u^2 \quad \dots (3)$$

$$\int f_y dV = N \cdot \frac{1}{2} \rho v^2 \Delta V + N_{elim} \frac{1}{2} \rho v^2 \Delta A \quad \dots (4)$$

where ΔV is control cell volume, and ΔA control cell area normal to velocity component. Coefficient N is representing packing resistance, N_{elim} is eliminator resistance [1, 3].

Mathematical model:

The mathematical model of transport processes of cooling tower is steady state, two dimension, turbulent and incompressible flows. The mass, momentum and energy conservation equations of air are given in rectangular coordinate system (x,y) and in two dimensions, while the mass and energy conservation equations of water are given only in water stream direction (y-direction). The cooling tower is a forced draft counter flow type and square cross section area, in which air passes upward through a falling spray of water. The geometric shape of the tower shown in Fig. (1).

Cooling tower governing equations are written in a general Cartesian partial differential form that is [7]:

$$\frac{\partial(\rho u \phi)}{\partial x} + \frac{\partial(\rho v \phi)}{\partial y} = \frac{\partial}{\partial x} \left(\Gamma_\phi \frac{\partial \phi}{\partial x} \right) + \frac{\partial}{\partial y} \left(\Gamma_\phi \frac{\partial \phi}{\partial y} \right) + S_\phi \quad \dots\dots (5)$$

Here, ϕ is the general depended different variable which may be a directional quantity such as velocity components (u,v), or scalar quantity such as air enthalpy, moisture content, water enthalpy, turbulent kinetic energy or rate of dissipation. S_ϕ is the source term which means

the source of heat, mass transfer, buoyancy force, resistance or pressure variation that allows fluid to flow. Γ_ϕ is the diffusion coefficient which means the dynamic viscosity in momentum equation, effective exchange coefficient in enthalpy or moisture fraction equations, kinetic energy or dissipation rate in turbulence equations, .

$$\Gamma_{eff} = \frac{\mu_{eff}}{\sigma_{eff}} \quad , \Gamma_k = \frac{\mu_{eff}}{\sigma_k} \quad , \Gamma_\epsilon = \frac{\mu_{eff}}{\sigma_\epsilon} \quad \dots\dots\dots (6)$$

$\mu_{eff} = \mu + \mu_t$, $\sigma_{eff} = Pr + \sigma_t$ (for energy equation), $\sigma_{eff} = Sc + \sigma_w$ (for moisture fraction equation). The left side of equation (5) is the convection term which mean the fluid transfer, the right side is the diffusion term which gives the variation in fluid property during the flow [7,11,12].

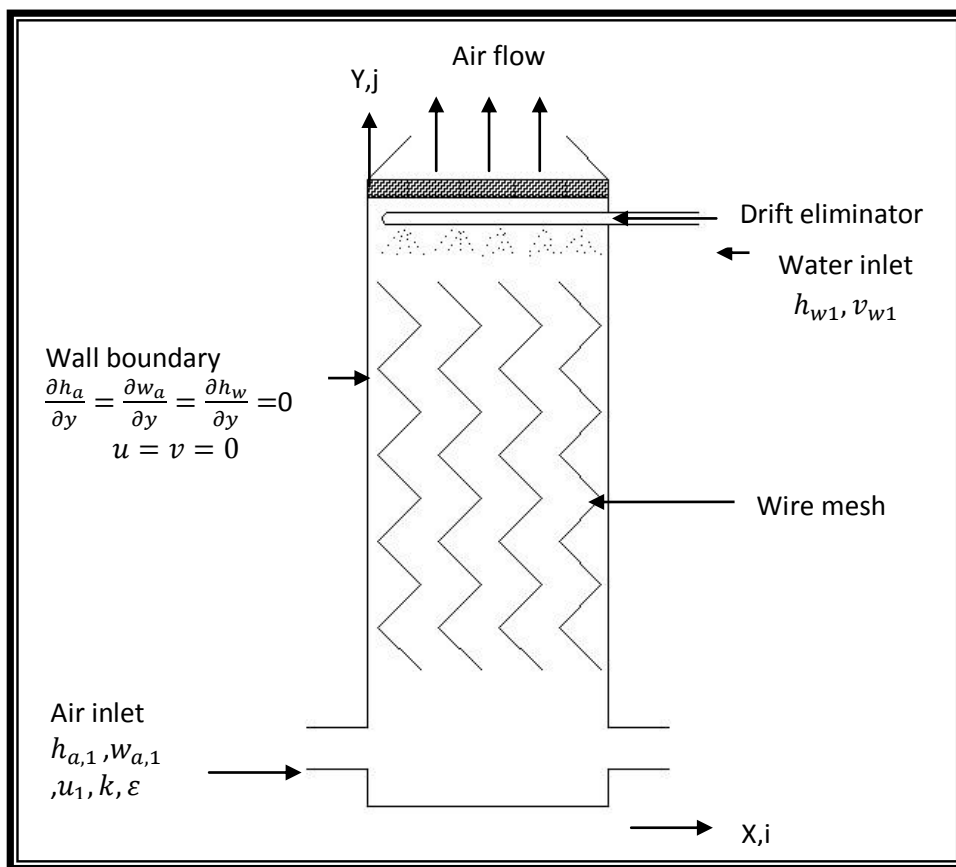

Figure (1) Geometric shape of the water cooling tower

The equation of state should be used due to determine the air density change throughout the tower [4]:

$$\rho = \frac{P \cdot w_G}{R \cdot (t_{adb} + 273)} \quad \dots\dots\dots (7)$$

The turbulence transport is needed in order to solve the governing equations; the turbulence transport was modeled by two equations (k-ε) model, the turbulent kinetic energy

(k), and the rate of its dissipation. The kinematic viscosity is related to these parameters by Kolmogrov-prandtl expression:

$$\nu_t = C_\mu \frac{k^2}{\varepsilon} \quad \dots\dots (8)$$

The empirical constants appearing in the (k-ε) equations are:

C_μ	$C_{1\varepsilon}$	$C_{2\varepsilon}$	σ_k	σ_ε	σ_t
0.09	1.44	1.92	1.0	1.3	0.9-1.0

The specific forms of various terms in the governing equations can be given as:

Equation	ϕ	Γ_ϕ	S_ϕ
The continuity equation of air	1	0	m_v'''
The continuity equation of water	1	0	$-m_v'''$
The momentum equation of air in X-direction	u	μ_{eff}	$\frac{\partial}{\partial x} \left(\mu_{eff} \frac{\partial u}{\partial x} \right) + \frac{\partial}{\partial y} \left(\mu_{eff} \frac{\partial v}{\partial x} \right) - \frac{\partial p}{\partial x} - f_x$
The momentum equation of air in Y-direction	v	μ_{eff}	$\frac{\partial}{\partial y} \left(\mu_{eff} \frac{\partial v}{\partial y} \right) + \frac{\partial}{\partial x} \left(\mu_{eff} \frac{\partial v}{\partial x} \right) - \frac{\partial p}{\partial y} - f_y - (\rho - \rho_{amb})g$
The energy equation of air	h_a	Γ_{eff}	q'''
The energy equation of water	h_w	0	$-q'''$
The moisture equation of air	w_a	Γ_{eff}	m_v'''
The turbulent kinetic energy equation	k	Γ_k	$G - \rho\varepsilon$
The rate of dissipation equation	ε	Γ_ε	$C_{1\varepsilon} \frac{\varepsilon}{k} G - C_{2\varepsilon} \rho \frac{\varepsilon^2}{k}$

Where, $G = \mu_t [2 \left(\frac{\partial u}{\partial x} \right)^2 + \left(\frac{\partial v}{\partial y} \right)^2] + \left(\frac{\partial u}{\partial y} + \frac{\partial v}{\partial x} \right)^2]$

Numerical computation procedure:

Since the governing equations are coupled and non linear, they have to be solved by means of an iterative procedure. An implicit solution scheme is employed and the solution of the governing equations using boundary conditions obtained by finite volume approach. A staggered grid system was followed. In this system the scalar quantities are located at the intersection of grid nodes and velocities are located at the boundaries of the control volumes of scalar quantities and the domain of tower is divided into main nodes which are (21x21). The resulting equation after discretization is:

$$\phi_p = \frac{a_W \phi_W + a_E \phi_E + a_N \phi_N + a_S \phi_S + S_{sc}}{a_W + a_E + a_N + a_S - S_{\phi p}} \quad \dots\dots\dots (9)$$

Where ϕ stands for any depended variable such as $u, v, h_a, h_w, w_a, k, \varepsilon$; and link coefficients a_W, a_E, a_N and a_S express the effects of convection and diffusion between the grid point,

P, and its neighboring grid nodes in East, West, North and South directions, respectively. S_{sc} and $S_{\phi p}$ are components of source term, S_{ϕ} , which is linearized as: $S_{\phi} = S_{sc} + S_{\phi p}$

The pressure is corrected to satisfy continuity at the end of each iteration. The hybrid scheme was used for the scalars and the velocity components. Under relaxation factor is applied to the velocity components to prevent instability and divergence due to nonlinearity in the momentum equation and also is used for pressure correction [13].

Experimental rig:

Experimental water cooling tower model comprise of tower of $(0.2 \times 0.2 \text{ m}^2)$ cross sectional and (1.22m) working height. Tower is fabricated out of a Perspex sheet for visualization of tower operation. A schematic and the photograph of the water cooling tower is shown in Fig.(2). Hot water spray arrangement and eliminator are provided at the top of the tower packing. The basin tank is $(0.2 \times 0.2 \times 0.2 \text{ m}^3)$ in size into which exit water falls and then passes to a heating tank. Hot water is pumped to the cooling tower and the flow is controlled by a control valve at the outlet of the pump; 4x(3 kw) electric heaters are installed with digital thermostat with thermometer (LAE with range -50 to 150 °C an accuracy ± 2 °C) to maintain a constant heating tank temperature.

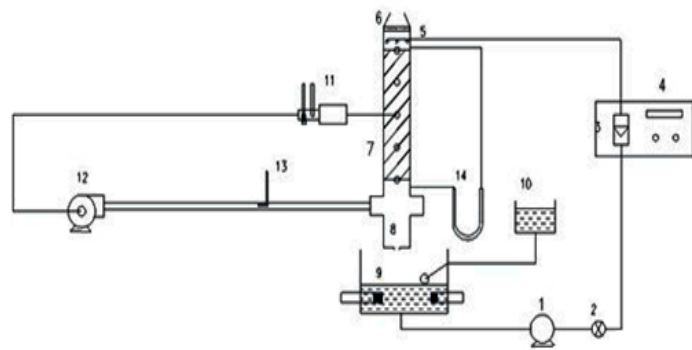
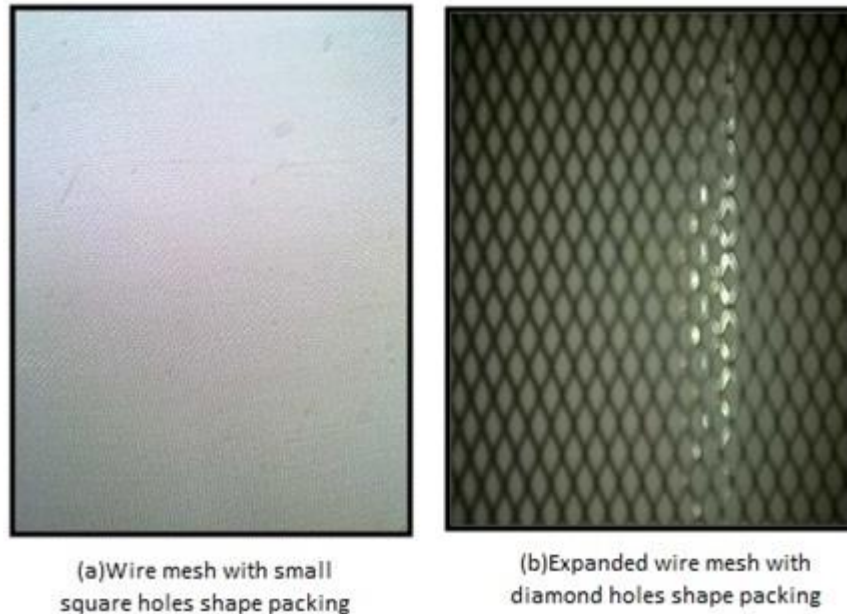

Figure (2) Experimental rig of forced draft counter flow water cooling tower.

1. Water pump, 2. Control valve, 3. Flow meter, 4. Temperature display and control unit, 5. Water spray, 6. Eliminator, 7. Cooling tower, 8. Water basin tank, 9. Water heating tank with heaters, 10. Make up water tank, 11. Psychrometer temperature, 12. Air blower, 13. Pitot tube, 14. U-tube manometer.

A (1 Hp) controlled centrifugal blower with plastic vane is used to supply variable flow air to cool the tower. Air line is provided with Pitot tube with U-manometer used to measure air velocity (uncertainty 0.03 m/sec) and water line is provided with a rotameter (range 0-7 Lit/min with uncertainty $- 0.02$ L/m) for air and water flow measurements respectively. Psychrometer is fitted to measure air condition at the entry and exit and five stations along the tower height. The water outlet temperature and five stations along tower are measured using thermometers (range 0-100°C with accuracy ± 0.1 °C). The Anemometer (smart sensor AR826) is used to measure the air inlet velocity in the cooling tower with range 0-45 m/sec and an accuracy $\pm 3\%$. A make up water tank is provided to measure the water level losses due to evaporation in the cooling tower.

In the experimental study, wire mesh was used as tower packing material. This type of wire mesh is considered as unique for film packing. The packs tested were of two types, wire mesh with small square holes shape packing (WMSSHSP) of $(1 \times 1) \text{ mm}^2$ and expanded wire mesh with diamond holes shape packing (EWMDHSP) of (7 mm length and 5 mm breadth). Figure (3-a) shows the photographic view of the two types wire mesh packs. The two types of wire mesh packs had vertical corrugations and the space between two sheets 40 mm as shown in Fig. (3-b). The length of the two pack is 80 cm.



a- Photograph is view of the two wire mesh packings
Figure (3-a)

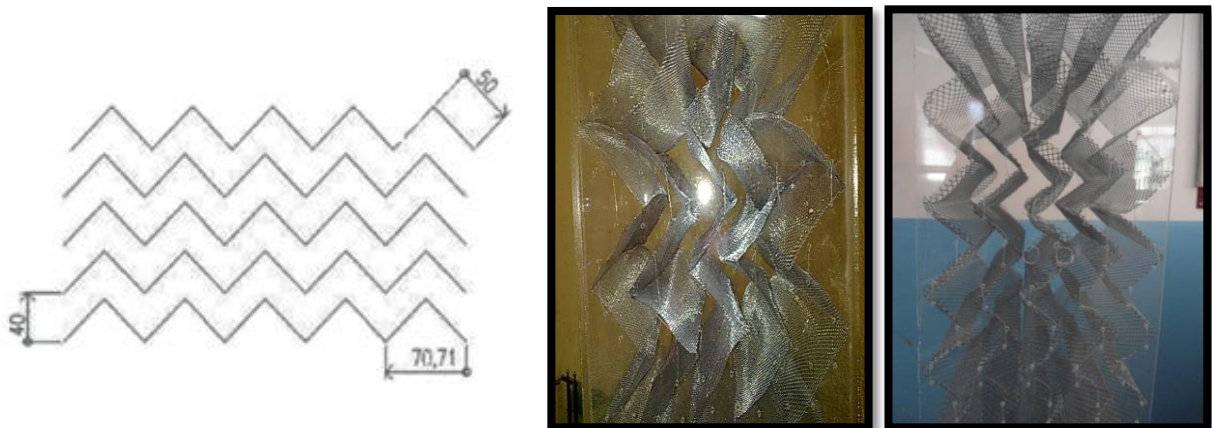

b- Schematic and Photograph is view arrangements of wire mesh of the two packings

Figure (3-b)

Experimental procedure and observation:

Water is allowed to circulate through the cooling tower when the heaters switch on until the temperature reaches a specified value. Different water temperatures are maintained by increasing or decreasing the heat input to the tank. After reaching this specified value of

temperature, the air allowed to force through the tower by forced draft fan. The air flow rate is maintained at different level by adjusting the control vane. When steady state condition reach, the inlet and outlet dry and wet bulb temperatures of air, and water temperature at five station along tower height were measured under variable operation parameters of liquid flow rate (L/min), and air flow rate (m³/sec) for two types of packs.

Results and discussion:

1. Experimental results:

The performance of a cooling tower depends on the tower characteristic, volumetric mass transfer coefficient, range of cooling, tower approach, the (L/G) ratio, and pressure drop. The equations reflect mass and heat balance at any point in the tower is:

$$\frac{Ka.V}{L} = C_w \int_{t_{w1}}^{t_{w2}} \frac{dt_w}{h_{sw} - h_a} \quad \dots\dots (10)$$

Mathematical integration of the equation is required and the procedure must account for relative motion. In examining equation (10), it can be seen from psychrometric chart that the vertical distance between the two curves represents the enthalpy difference ($h_{sw} - h_a$) in the integral of equation (10) [14]. Thus a second curve can be plotted for $1/(h_{sw} - h_a)$ as a function of the local water temperature, and the value of the integral can be determined by obtaining the area under the curve. The resulting quantity (Ka.V/L) known as a tower characteristic, is thus the function of the inlet and exit air wet bulb temperatures and the inlet and exit water temperatures. These can be expressed in terms of the approach temperature, the temperature range of the water, and the ratio of the water flow to the air flow rate. However the log-mean-enthalpy method based on the inlet and outlet enthalpy differences would underestimate the value of the tower characteristic. The tower characteristics can be then calculated from equation below:

$$\frac{Ka.V}{L} = \frac{t_{w2} - t_{w1}}{\Delta h_m} \quad \dots\dots (11)$$

Where (Δh_m) is the difference in enthalpy of the inlet and outlet which is generally known as the enthalpy mean driving force [5].

In this study, the correlation characteristic equation of the cooling tower is obtained by plotting values of ($\frac{Ka.V}{L}$) versus the ratio of water to air flow rates (L/G),

$$\frac{Ka.V}{L} = \lambda \left(\frac{L}{G}\right)^{-n} \quad \dots\dots (12)$$

The following is the procedures to obtain this equation:

- Calculate the flow ratio (L/G) by determine the mass flow rate of air and water.
- Tabulate specific enthalpy of the bulk air and boundary layer for inlet and outlet conditions.
- Calculate the overall mean driving force.
- Calculate the respective value of (KaV/L) and plot graphically against the ratio (L/G).
- Logarithmically, plot (KaV/L) against (L/G), and draw the best straight line through the points.

At last, the constants (λ & n) and the characteristic equation were estimated. The correlation characteristic equation for the pack type (WMSSHSP) is:

$$\frac{Ka.V}{L} = 0.183 \left(\frac{L}{G}\right)^{-0.624} \dots (13)$$

$$\frac{Ka.V}{L} = 0.3807 \left(\frac{L}{G}\right)^{-0.762} \dots (14)$$

Figure (4) illustrates the influence of air mass flow rate on volumetric mass transfer coefficient (Ka) at constant water mass flow rate for two packs. The value of that (Ka) increases with increasing air mass flow rate for two type's packs, which means increase evaporation from water into air stream. It is also clear that (Ka) for (EWMDHSP) increase with (55 %) than (WMSSHSP).

The relation of the volumetric mass transfer coefficient (Ka) against (L/G) at constant air mass flow rate, is depicted in Figure (5). It can be observed that the (Ka) increases (56.7%) for (EWMDHSP) than (WMSSHSP) with increasing water mass flow rate and this lead to decrease the performance of cooling tower with increasing (L/G).

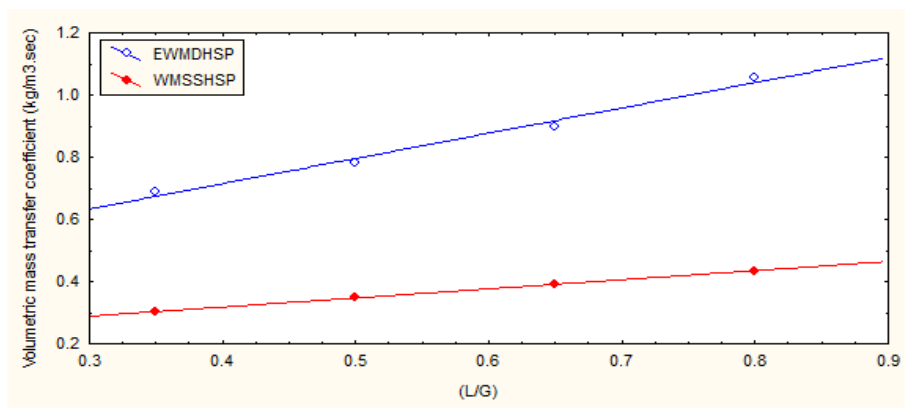

Figure (4): Variation of volumetric mass transfer coefficient with air mass flow rate for the two packs

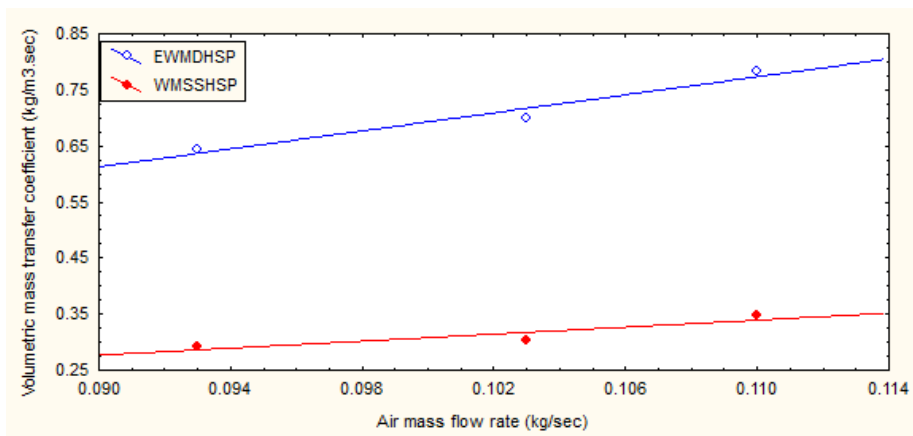

Figure (5): Variation of volumetric mass transfer coefficient with (L/G) ratio for two packs.

Tower approach means the difference between the outlet water temperature and inlet air wet bulb temperature, and the range of tower is the difference between inlet and outlet water temperature. It can be observed from Figure (6) that high air flow rate gives low approach and high range for (EWMDHSP), compare with (WMSSHSP) which leads to best performance for (EWMDHSP).

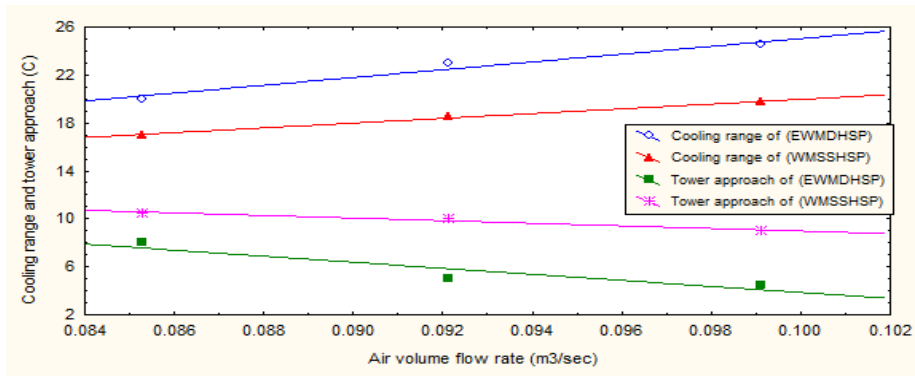

Figure (6): Variation of cooling range and tower approach with air volume flow rate for two packs.

Figure (7) shows the variation of the pressure drop across the cooling tower with air mass flow rate. It can be seen that the pressure drop tends to increase as the air mass flow rate increases. Also, the pressure drop of (WMSSHSP) is higher with (43.9%) than that for (EWMDHSP) because the former pack is higher resistance to air travel in the tower than the latter pack.

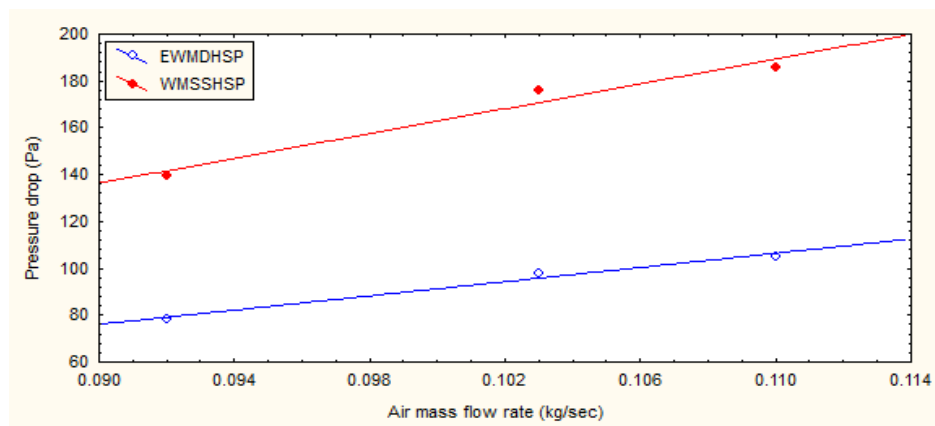

Figure (7): Variation of pressure drop with air mass flow rate for two packs.

At given operating conditions, the outlet water temperatures measure tower capabilities. Figure (8) shows the outlet water temperature variation with (L/G) ratio for different water flow rates. It is clear from this figure that cooling water output temperature is lower in (EWMDHSP) compared with (WMSSHSP).

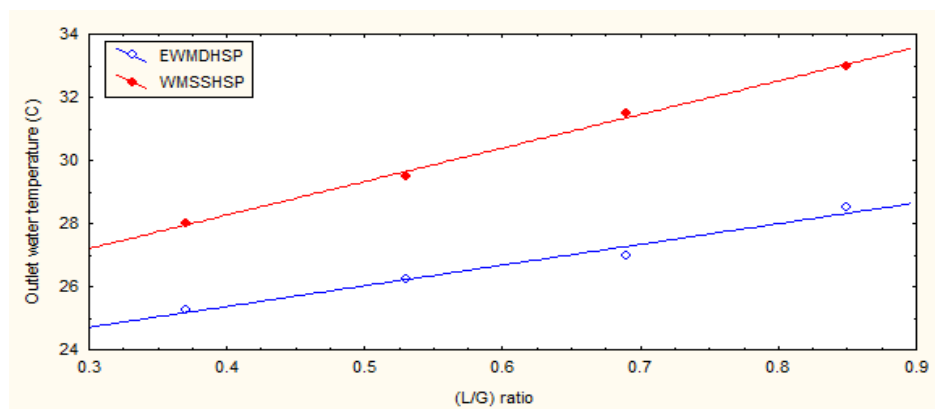

Figure (8): Variation outlet water temperature with (L/G) ratio for two packs.

Figure (9) demonstrate the comparison between the present work and other experimental works according to the relationship between tower characteristic versus flow ratio. A good agreement in results obtained between the present work and other works.

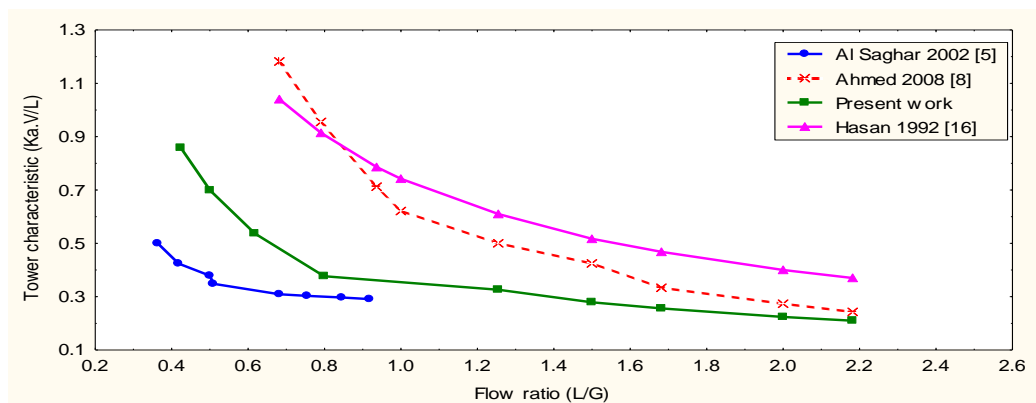

Figure (9): comparison the effect of flow ratio (L/G) on the tower characteristic of (EWMDHSP) of the present work with other work.

2. Numerical results:

The results of the numerical solution based on (2-D) model used (CFD) technique to compute the rate of heat and mass transfer for both types packing are as follows:

Figures (10 &11) gives the variation in the rate of heat and mass transfer for both packs respectively. It is shown that the rate of heat and mass transfer are increased gradually along the cooling tower and become a maximum at top of tower, also the rate of heat and mass transfer for the (EWMDHSP) are higher than that for the (WMSSHSP) and this is because the heat energy losses from water and the rate of evaporation are high at high stages of tower and higher for (EWMDHSP) than the other.

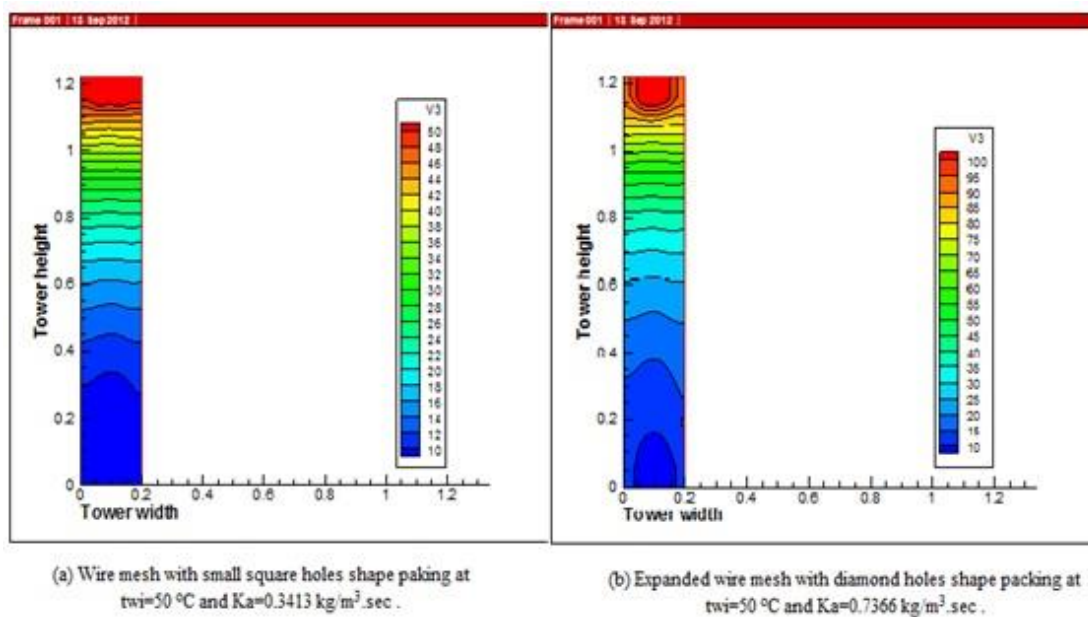

Figure (10) rate of heat transfer distribution of forced draft counter flow water cooling tower.

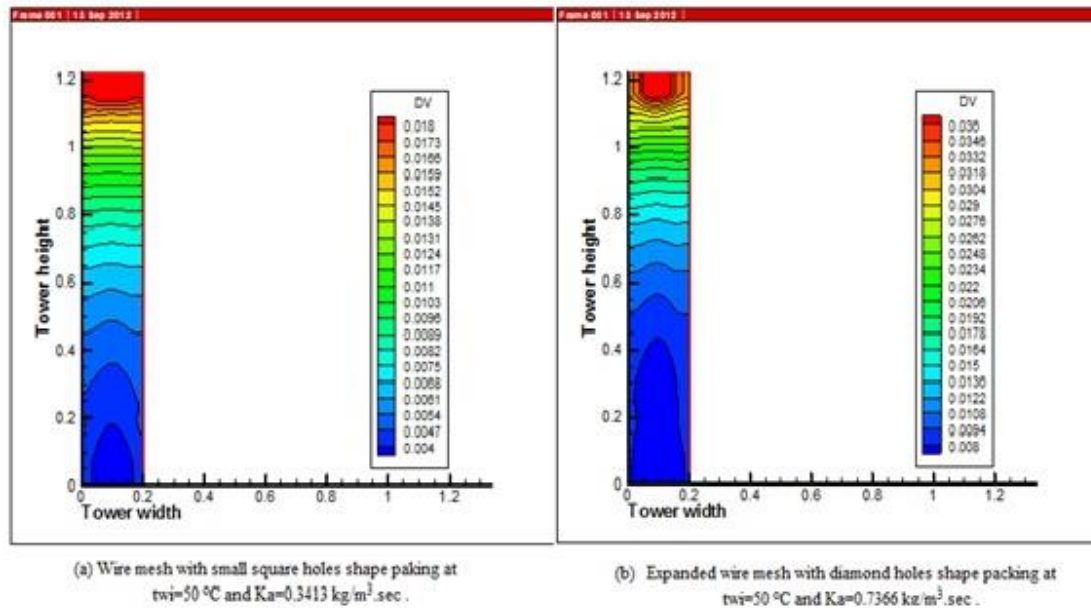
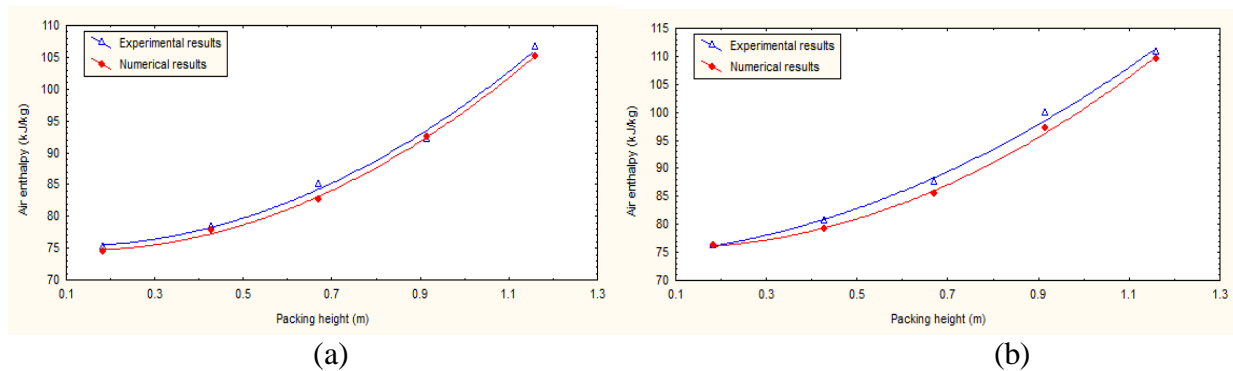

Figure (11) rate of mass transfer distribution of forced draft counter flow water cooling tower.

Validation of the computer program:

In order to verify the computer program results, which represent a numerical simulation for the counter flow cooling tower, a comparison between the numerical and experimental results as shown in Figure (16). It is shows the comparison between the experimental and numerical air enthalpy along the tower height for two types of packs. The air enthalpy increases gradually along the tower height and this increasing is due to the heat transfer from warm water to bulk air. Acceptable agreement was observed.



(a) Wire mesh with small square holes shape packing at $t_{wi}=53\text{ }^{\circ}\text{C}$ and $Ka=0.2451\text{ kg/m}^3\cdot\text{sec}$.

(b) Expanded wire mesh with diamond holes shape packing at $t_{wi}=53\text{ }^{\circ}\text{C}$ and $Ka=0.3313\text{ kg/m}^3\cdot\text{sec}$.

Figure (12) the numerical and experimental results variation with air enthalpy along cooling tower height for two packs.

Conclusions:

Numerical model and experiments were conducted to investigate the effect of the air flow rate and water flow rate on the performance of water cooling tower. Numerical model and experiments were carried out to compare the performance of the two types wire mesh packs with different configuration. From numerical and experimental results we concluded that:

- 1- The (EWMDHSP) have better performance than (WMSSHSP). That is due to the pressure drop of (WMSSHSP) is higher than that for the (EWMDHSP) due to air resistance of the former pack is higher than the latter pack.
- 2- In the (WMSSHSP) configuration the discharged of water is low, and of air flow at the top of the tower is become water abundance, with poor water at the bottom of the tower compare with (EWMDHSP). The air to water contact is better in (EWMDHSP), so better heat transfer has been occurred and the outlet water temperature is reduced compared with (WMSSHSP).
- 3- From the experimental study the cooling tower characteristic and volumetric mass transfer coefficient are higher in (EWMDHSP) due to high contact area of water to air.
- 4- Reasonable agreement is obtained from the comparison between the results obtained from the experiments and those obtained from the numerical program.

Reference:

1. Majumdar A. K., Singhal A. K. and Spalding D. B. " Numerical modeling of wet cooling tower – Part 1: Mathematical and Physical Models ", ASME Transaction, Journal of Heat Transfer, Vol. 105, 1983, pp. 728-735.
2. Al Habobi, M. A. "Performance of different packing configurations in a counter flow water cooling tower ". M. Sc. Thesis. College of Engineering. University of Baghdad. (1995).
3. Stefanovic V., Ilic G., Vukic M., Radojkovic N., Vuckovic G., and Zivkovic P. " 3D Model in heat and mass transfer processes in wet cooling towers " Mechanical Engineering , Vol. 1, 2001, pp. 1065-1081.
4. Abdullah A. N. "thermal analysis and numerical modeling for open type forced draft water cooling towers ". M. Sc. Thesis College of Engineering. University of technology. (2002).
5. Al Saghar E. O. "An improvement investigation of water cooling tower performance". M. Sc. Thesis, Al Rashed College. (2003).
6. Mehdi, Q. S. "Numerical and Experimental Investigation for a Counter Flow Cooling Tower Performance ". Ph.D. Thesis. University of Technology. 2004.
7. Al Waked R. And Behnia M. "CFD simulation of wet cooling towers" Applied Thermal Engineering. Vol. 26, 2006, pp. 382-395.
8. Ahmed A. "Numerical and Experimental study of heat and mass transfer performance of a counter flow water cooling towers" M. Sc. Thesis Technical College of Baghdad. (2008).
9. Ramkumar R. and Ragupathy A. "Thermal performance of forced draft counter flow wet cooling tower with expanded wire mesh packing" IJTPE Journal. Vol. 3, 2011, pp. 19-23.
10. Merkel F., "Forschungsarbeiten", Heat and Mass Transfer Handbook, VDI, No. 275, 1925, pp: 1-48.
11. Sureshkumer R., Kale S. R. and Dhar P. L. "Heat and mass transfer processes between a water spray and ambient air – II. Simulations ". Applied thermal engineering . Vol. 28, 2008, pp 361-371.

12. Yang x. l., Sun F. Z., Wang K., Shi Y. T., and Wang N. H. " Numerical simulation of flow fields in a natural draft wet cooling tower " Journal of Hydrodynamics . Vol. 19, 2007, pp 762-768.
13. Patenakar S.V. "Numerical Heat Transfer and Fluid Flow ". 4th Edition MC Graw Hill Book Co. (1980).
14. Fraas A. P. and Necatiozisik M. "Heat exchanger design" John Wiley 2 sons, Inc. New York. (1965).
15. Coleman H. W. and Steele W. G. "Experimentation, Validation, and Uncertainty Analysis for Engineers ". 3rd Edition, John Wiley and Sons, Inc. (2009).
16. Hasan A. A., "Parametric Investigation of Counter Flow Water Cooling Tower", M. Sc. Thesis, University of Baghdad, (1992).

The work was carried out at the Technical college / Baghdad